

Anlage 10

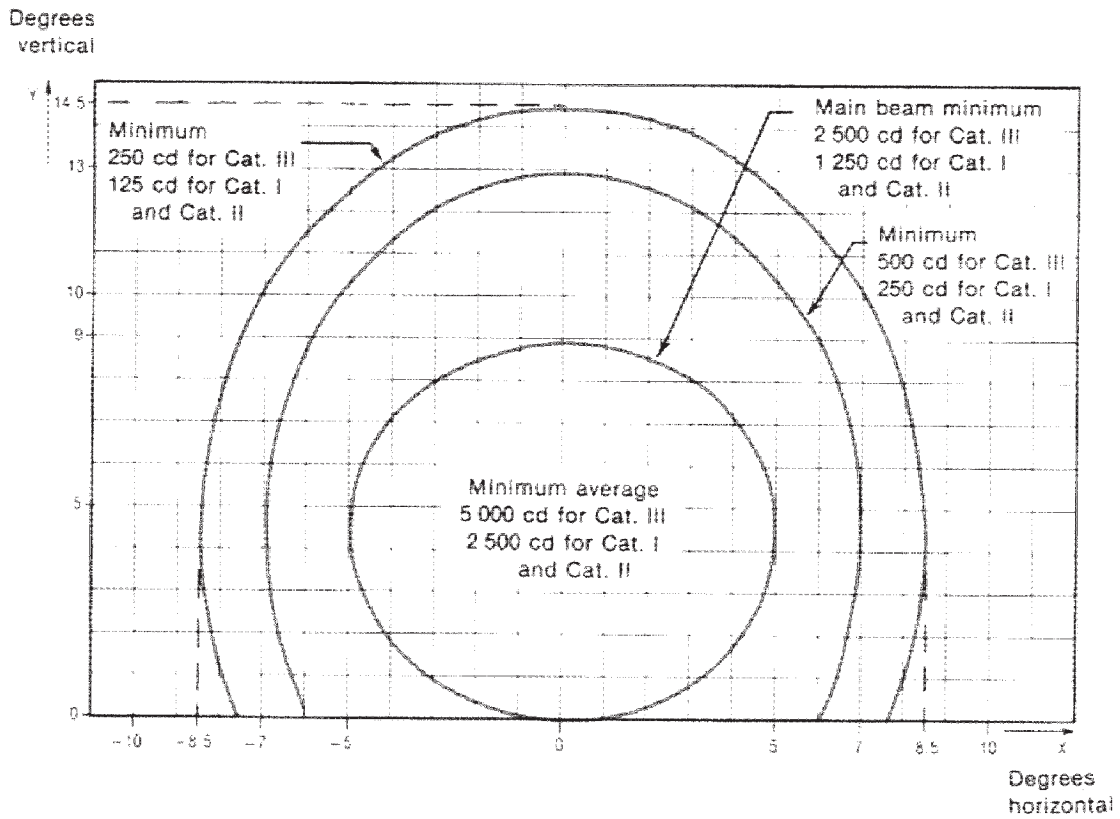

Notes:

1. Curves calculated on formula $\frac{x^2}{a^2} + \frac{y^2}{b^2} = 1$
2. For red light multiply values by 0.15
3. See collective notes for Figures 2.1 to 2.11.

| | | | |
|---|-----|-----|-----|
| a | 5.0 | 7.0 | 8.5 |
| b | 4.5 | 8.5 | 10 |

Figure 2.7 Isocandela diagram for runway centre line light with 15 m longitudinal spacing (white light)